

ANKE - The Reliable Medical Equipment Manufacturer



ANATOM 64 Clarity 64-slice spiral CT

Proposal



ANATOM 64 Clarity AI-based 64-slice Spiral CT Performance

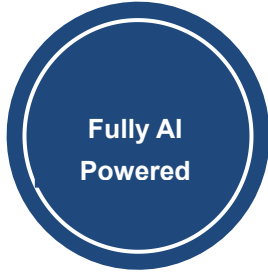

ANATOM 64 Clarity uses a full-flow artificial intelligence platform from patient positioning, scanning, dose control, artefact suppression, energy spectrum imaging, image noise reduction and image post-processing to diagnostic assistance, making "artificial intelligence technology" a real assistant for operating technologists and diagnosing doctors, improving examination efficiency and diagnostic accuracy comprehensively.

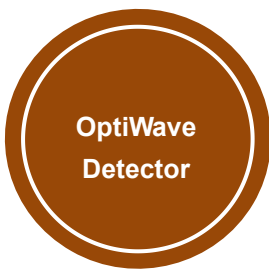
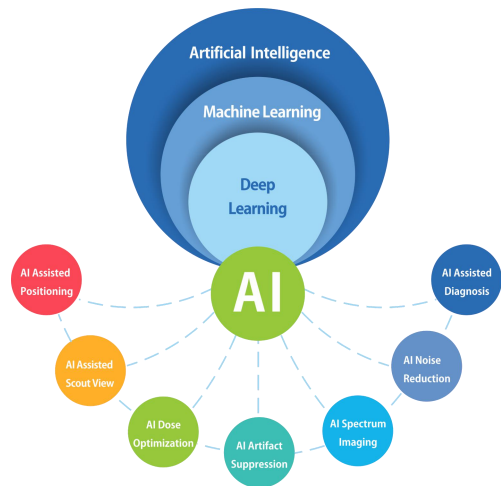

ANATOM 64 Clarity adopts ANKE's self-developed 2-cm OptiWave detector, which is organised and supported by the Ministry of Industry and Information Technology of the People's Republic of China. It is designed with an isofocal hardware structure, combined with the AccuShape^{3D} stereoscopic anti-scattering grids, so that the distance from the X-rays to the corresponding receiving unit of the detector is the same. In addition of obtaining high quality, high resolution images, it also achieves 2cm wide body coverage in both axial and spiral scanning, which not only improves examination efficiency but also enriches clinical applications.

Field replaceable unit (FRU) design, the key parts be easily disassembled, all are in order to achieve the purpose of simplifying the maintenance operation and reducing the maintenance time. Each detector module can be independent of disassembly and replacement which makes the detector module

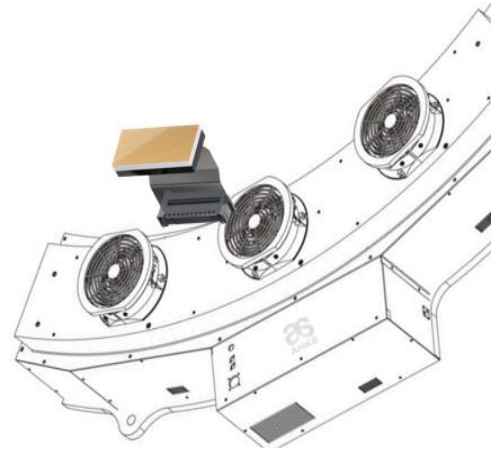

maintenance and system upgrades completed quickly at the scene. It can reduce the user's operation and maintenance costs, on the other hand, ensure the equipment with continuous upgrading ability.

Under the same conditions, the service life of the CT detector depends on the decay amplitude of the output signal induced by accumulated exposure dose over time. OptiWave detector has been designed of the optimal structure, even after 10 years of use, the

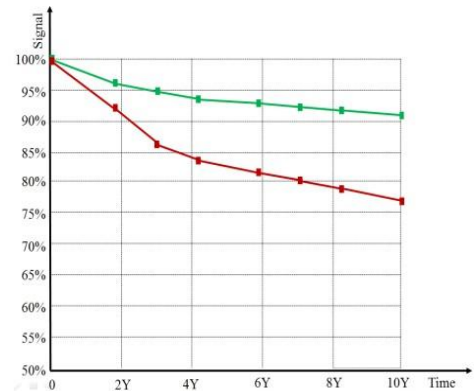

radiation damage caused by signal attenuation is less than 8%. It not only prolongs the service life of the detector but also ensures the users' maximum return on investment.



With the help of a deep binocular visual perception system-AccuPositioning, deep learning is used to give the device the cognitive ability and behaviour to enable the system to intelligently identify multiple positioning points on the human body and display the scanning site on the intelligent touch screen terminal. As well it enables automatically identify the isocentric position of the proposed scanning site to achieve precise and intelligent patient positioning. Through the application of this technology, it not only substantially improves the accuracy of patient positioning and reduces operational errors, but also better protects patients from the risk of collision and accidental injury. More importantly, the

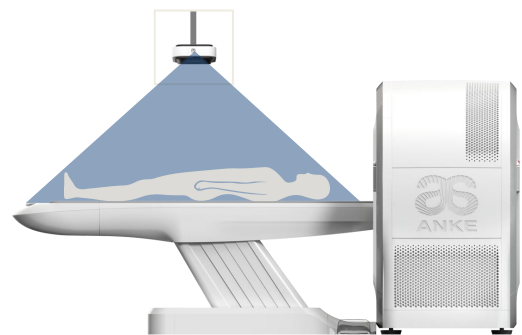

As well it enables automatically identify the isocentric position of the proposed scanning site to achieve precise and intelligent patient positioning. Through the application of this technology, it not only substantially improves the accuracy of patient positioning and reduces operational errors, but also better protects patients from the risk of collision and accidental injury. More importantly, the



Center recognition



intelligent positioning advantage

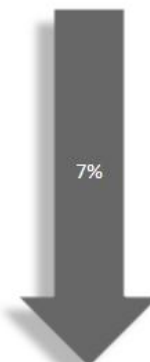
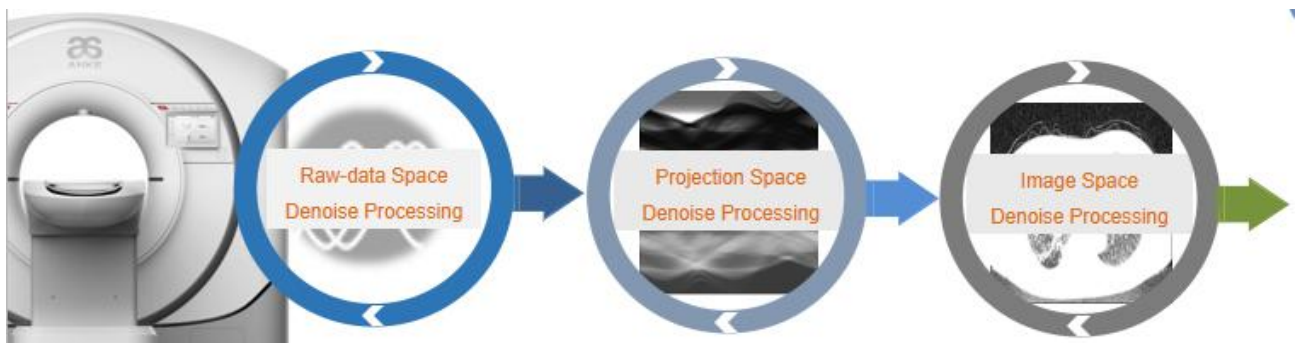

image noise

AccuPositioning system also helps the technician to standardise operations and mitigate the increase in radiation dose to the patient's surface due to inaccurate positioning, while further reducing image noise, reducing artefacts and improving image quality.



ANATOM 64 Clarity uses the world leading Admir^{3D} iterative reconstruction technology, through innovative designs of data sampling technology, original data reconstruction technology, post-processing technology and others, Admir^{3D} not only can fully extract the effective data information, but also the data information In the original data field, the corrected projection field and the image field three different data space for multiple recycling, processing, to increase the number of original data reconstruction. That can reduce the X-ray dose and the image noise but Improve the image quality, while access to various parts of high-resolution, low dose of clinical images.



Traditional CT in order to improve the image quality can only be achieved by increasing the dose of X- ray, but at the same time the patient's radiation dose will also be greatly increased. In order to better solve the problem of image quality and radiation dose, Admir^{3D} accurately constructs and describes the photon characteristics of the signal through a unique mathematical model, iterates it in the original data domain, the corrected projection domain and the image domain. Admir^{3D} processing effect can be performed from 1 to 100 levels, corresponding to the noise reduction requirements.



Admir^{3D} fast reconstruction engine technology

Admir^{3D} iteration technology is based on the original data field, the projection field after correction and image field, which will no doubt greatly increase the system's computing load. According to this feature, Admir^{3D} platform is equipped with Intel 8-core dual-CPU parallel processor and 64G RAM. Its powerful data processing capability allows the system to mass data processing speed increased nearly 5 times.



Gantry's built-in camera- "Eagle Eye" allows real-time monitoring of the patient's status, together with the AI-based AccuClear function, and enables intelligent real time image artifact correction. The novel design of the built-in camera allows for both remote observation of the person being examined and also real-time motion recognition. With AI, correction of motion artefacts can be performed. It is particularly helpful for scanning patients who have involuntary movements, subconscious movements, etc.



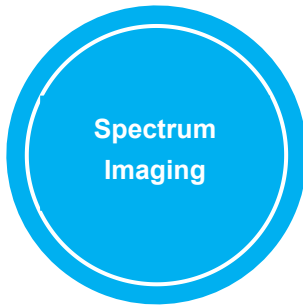

Spectrum
Imaging

Spectrum imaging was implemented in 1973 by Hounsfield, the inventor of CT, by using two tube voltages for sequential scanning to distinguish between substances of different atomic number. Alvarez and Macovski, the first to explain the principle of CT dual energy imaging, pointed out that X-rays with mixed energy penetrate the body at the same time and that the Photoelectric and Compton effects produced in different substances can be used for CT Spectrum imaging.

There are two commonly used methods of X-ray energy decomposition, one is based on projection data domain, the other is image data domain. Studies have shown that the former is more accurate and facilitates the removal of artefacts, especially if the data is perfectly matched in time and space.

Currently, there are a number of proven CT energy imaging modalities available on market, including dual-source energy, high & low-kV switching, dual-layer detector and dual-helix/dual-axis.

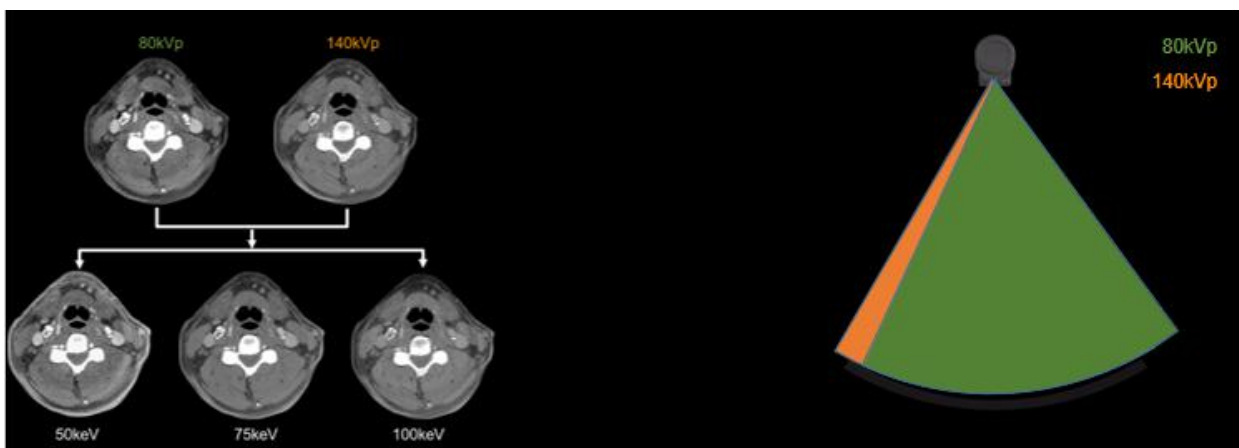

Among them, dual helix/dual axis energy imaging has certain limitations (limited to sites or organs with autonomous motion) and is often used in low-end CT products; while dual source CT, dual layer detector CT and kV switching energy Spectrum CT can obtain good energy separation effect, but due to the high acquisition and maintenance costs, they cannot be widely used and promoted. In view of this, we have introduced the "Dual-scan Spectrum Imaging" technology based on conventional X-ray generation systems and OptiWave detectors and which is combined with Adose mA modulation technology and encoder assisted projection data alignment to achieve energy separation.



CCTA imaging, as the most important clinical application of post 64-row CT, has always been the most important technical point of interest for users during the procurement and use process. How can the success rate be improved? How can we make the examination more comfortable? How can we meet the needs of patients with high heart rates? How to meet the needs of patients with irregular heart rates? How to achieve low radiation dose and low contrast dosage for coronary imaging? Can energy spectrum imaging be applied to CCTA imaging? How can coronary artery analysis and diagnosis be performed quickly? How can we provide more accurate information to clinicians? ...All these questions are the difficulties and pain points encountered by the majority of medical technicians in actual clinical work. In order to effectively solve these objective and practical problems, ANKE uses advanced hardware, new algorithms and leading AI imaging technology in the ANATOM 64 Clarity CT, taking advantage of the 8cm wide



body detector, to bring patients a high success rate and high comfort of the examination experience, providing operators and clinicians with an easy, fast and comfortable way to diagnose and diagnose. It provides easy, fast and comfortable operation and diagnosis for both the operator and the clinician.

AccuPitch coronary adaptive pitch technology, combined with AccuGating intelligent gating trigger technology and Adose mA current modulation technology, enables CCTA imaging at ultra-low dose and low contrast agent dosage perfectly adapted to patients with high heart rates and complex rhythms with the support of motion correction technology.

Note: * optional

Typical Clinical Solutions

Image quality and clinical application are the standards to test the quality of imaging equipment, CT is also the development of focusing clinical needs of continuous innovation and change. Anke has always been adhering to the "Bring science and technology to healthcare" concept to promote the CT technology to leading position in the domestic industry's, and continue to expand the clinical application of new areas. The ANATOM 64 Clarity has the most complete clinical applications in the industry. The newest features of the ANATOM 64 Clarity include a variety of functions including neurology, orthopaedics, gastroenterology, respiratory, internal medicine, and so on.

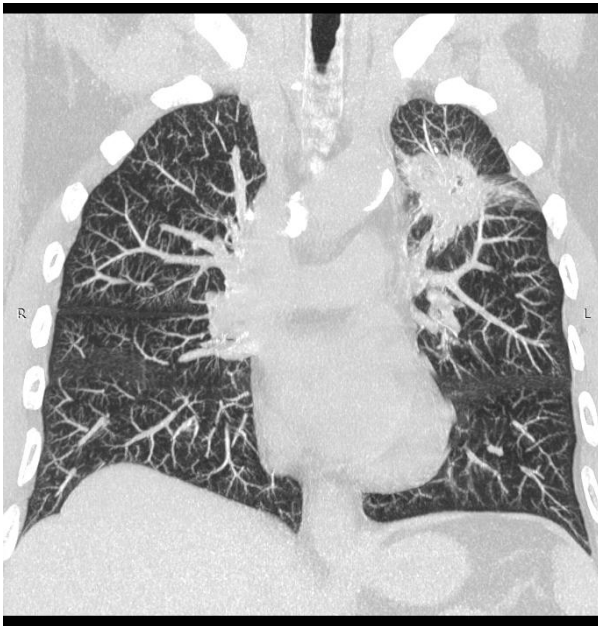

High resolution lung image

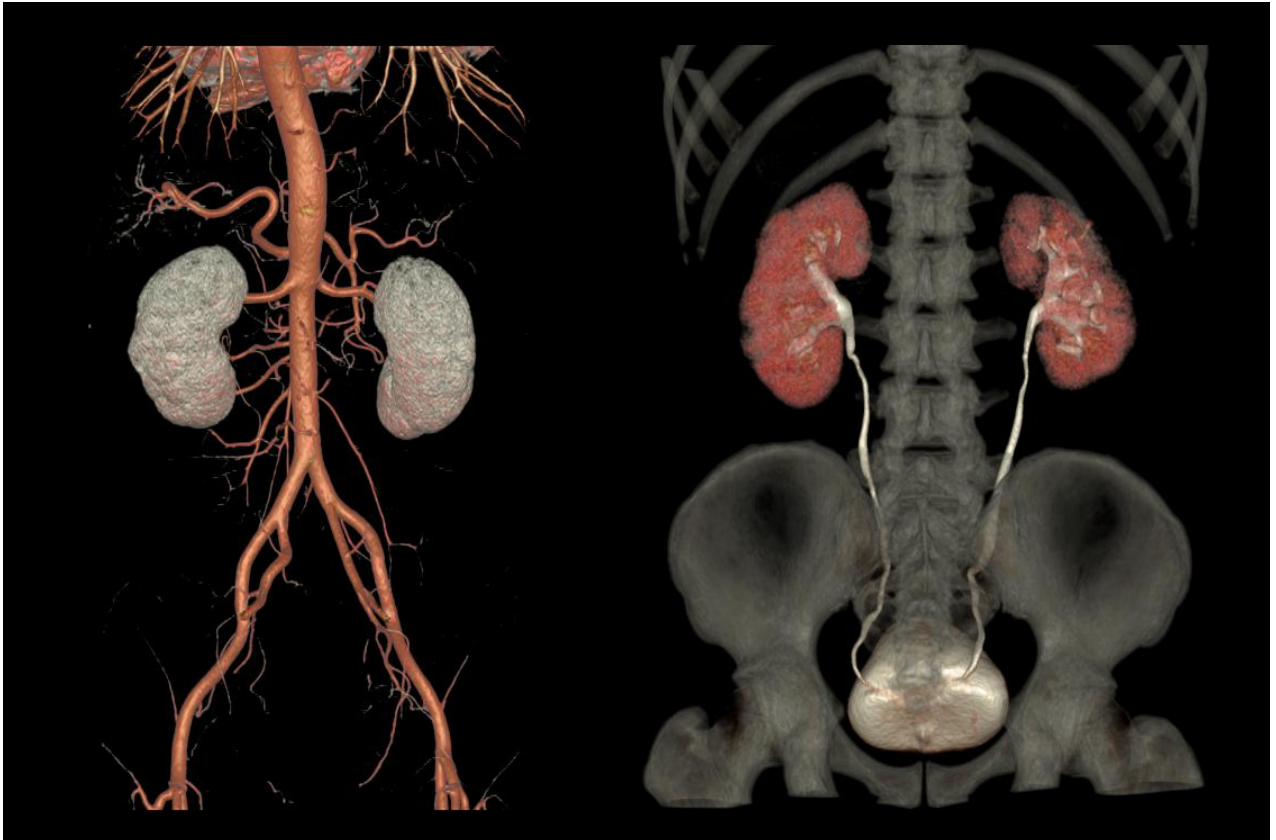

Abdomen CTA and CTU images

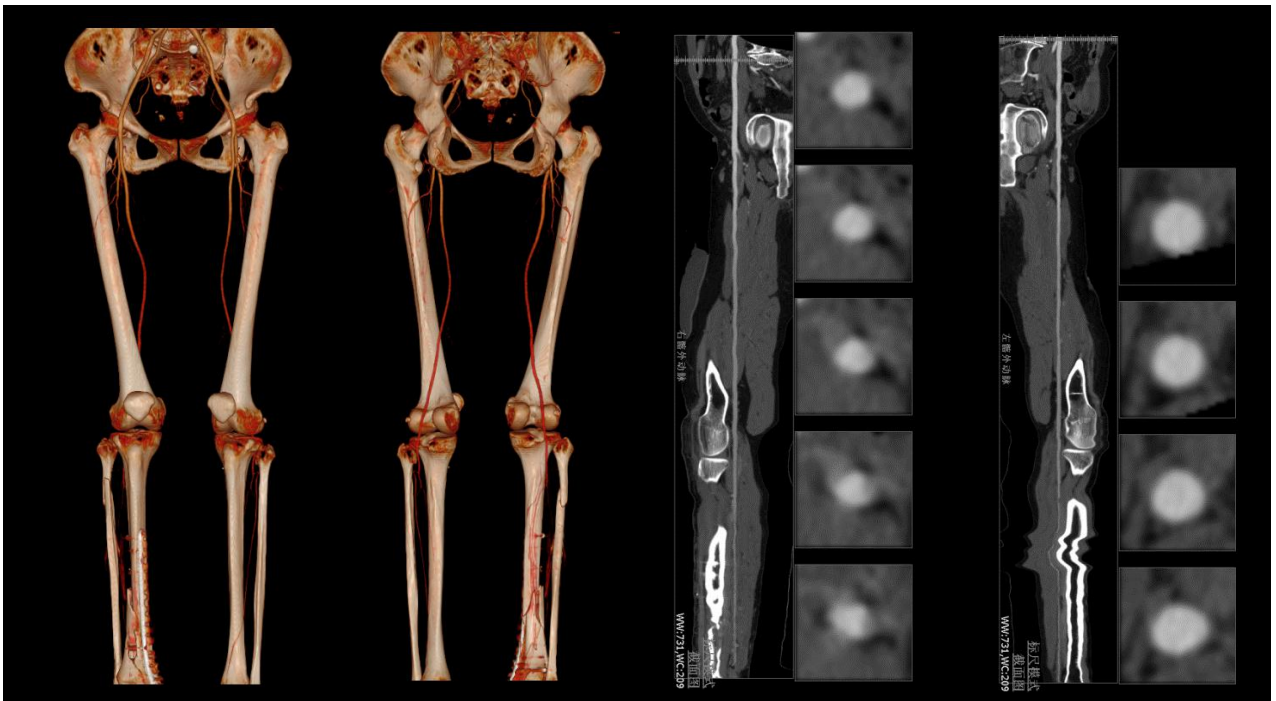

Low Extremity CTA

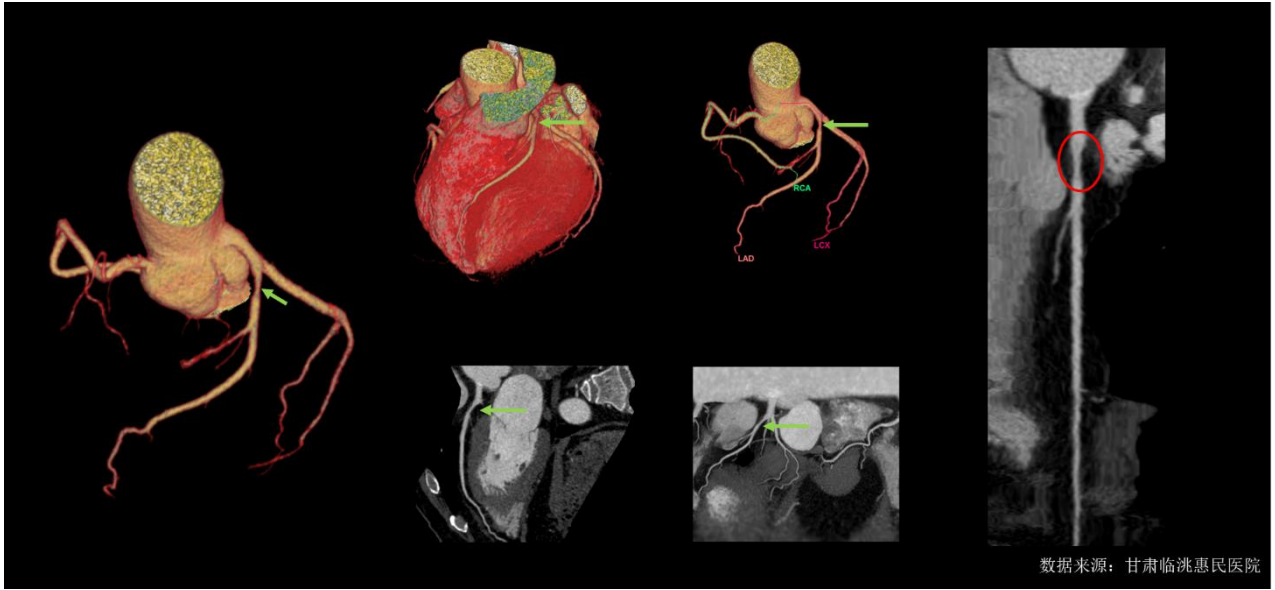

Coronary angiography

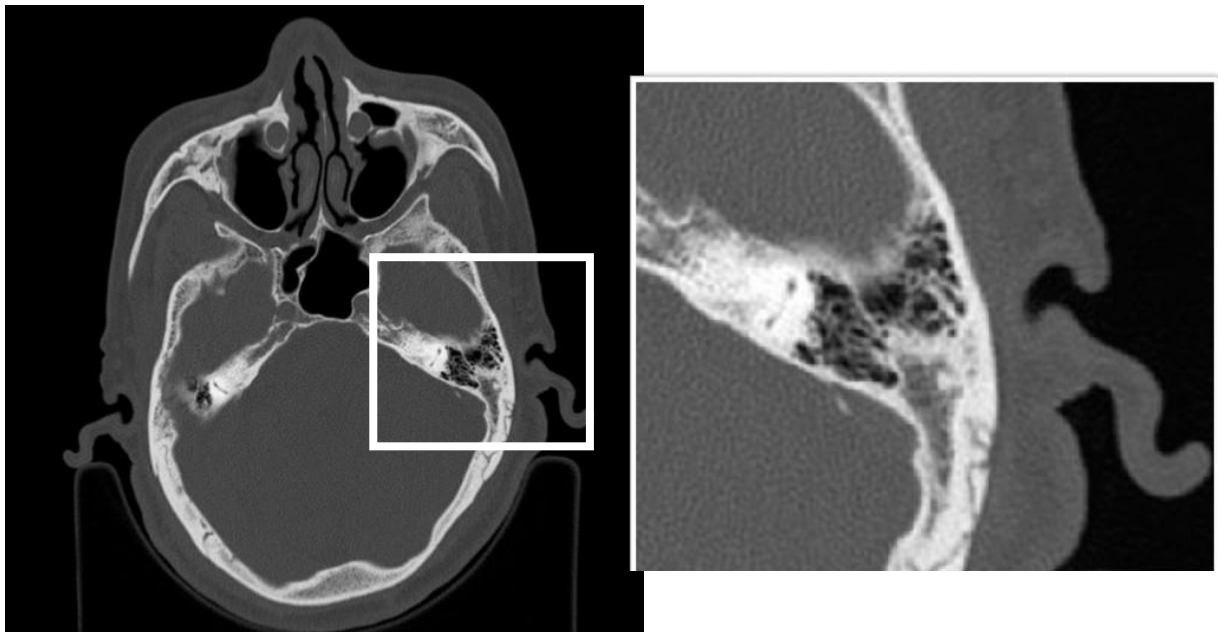

Inner-ear image

Note: some of above mentioned function, technologies and applications are optional, for standard configuration please refer to configuration list.



INSIGHT INTO LIFE

Shenzhen Anke High-tech Co., Ltd.

Address: Block B, LingYa Industrial Zone, Tangtou No.1 Road,
Bao'an District, Shenzhen, 518108, P.R. China

Tel: +86-755-21622518 26688889

Fax: +86-755-26695307 26685908

Email: anke@anke.com

Specifications and appearance of the equipment may change without prior notice. ANKE reserves the right of final interpretation.



Twitter: ANKE (@ankeint)



Facebook: ANKE (@ankemri)



Instagram: ANKE (@ankemarcom)